

ZRM 6006

Retroreflectometer R_L/Qd

Instruction Manual
from Firmware v.1.3



Exclusion of liability	Error! Bookmark not defined.
1 Description of device	6
2 Safety information.....	7
2.1 Symbols used.....	7
2.2 Safety notes and hints	7
3 Delivery of device	8
3.1 Damages during carriage	8
3.2 Shipment	8
3.3 Standard delivery	9
3.4 Carrying case	10
4 Device overview	11
5 Setting up	12
6 Calibrate	12
6.1 Calibrate.....	12
6.2 Calibration standard	13
6.3 Cleaning of the calibration standard	13
7 Measure.....	14
7.1 Carrying out exact measurements.....	14
7.2 Measuring profiled markings from 5-12 mm	16
7.2.1 Getting started	17
7.2.2 Measurements with profile distances under 300 mm	18
7.2.3 Measurements with profile distances over 300 mm	20
7.2.4 Explanation of profile measurements.....	23
7.3 Wet measurements	24
8 Built-in battery and charging.....	25
8.1 Battery	25
8.2 Battery status indication on the display	25
8.3 Charging.....	25
8.3.1 Charging status indication / charging cycle.....	25
9 Maintenance	26
9.1 Maintenance carried out by the user	26

9.2 Cleaning	26
10 Errors	27
11 Graphical illustration of the measuring principles.....	28
11.1 Night visibility R_L	28
11.2 Day visibility	28
12 Technical specification.....	29
Glossary	30

Exclusion of liability

Illustrations, descriptions as well as the technical specifications conform to the instruction manual on hand at the time of publishing or printing.

However, Proceq SA policy is one of continuous product development. All changes resulting from technical progress, modified construction or similar are reserved without obligation for Proceq SA to update.

Some of the images shown in this instruction manual may be of a pre-production model and/or are computer generated; therefore, the design / features of the delivered product may differ in various aspects.

The instruction manual has been drafted with the utmost care. Nevertheless, errors cannot be entirely excluded. The manufacturer will not be liable for errors in this instruction manual or for damages resulting from any errors.

The manufacturer will be grateful at any time for suggestions, proposals for improvement and indications of errors.

1 Description of device

The Retroreflectometer ZRM 6006 is a portable budget priced user-friendly entry level retroreflectometer with one button operation for measuring night (R_L) and day (Q_d) visibility of road markings.

In particular, this instrument has the following features:

- Focused on the core functions to keep the reflectometer simple and inexpensive
- The determination of both night and day visibility in all ambient lighting conditions, Day and Night
- Ultrafast retroreflection measurement (R_L and Q_d) in about only 2 seconds
- Easy and clearly arranged handling with only one operating button and one on/off button
- Transflective display for optimal readability
- Long battery life
- Easy and quick calibration
- Suitable for all type of road markings
- Integrated temperature ($^{\circ}\text{C}$ / $^{\circ}\text{F}$) and relative humidity (rH) measurement
- Low weight

2 Safety information

2.1 Symbols used



This note comprises instructions needed to follow directions, specifications, proper working procedure and to avoid data loss, damage or destruction of the instrument.



This note signifies a warning about dangers to life and limb if the apparatus is handled improperly. Observe these notes and be particularly careful in these cases. Also inform other users on all safety notes. Besides the notes in this instruction manual the generally applicable safety instructions and regulations for prevention of accidents must be observed.

2.2 Safety notes and hints



It is strictly forbidden to open the housing of the ZRM 6006. If not observed, all the guarantee and liability claims to Proceq SA will be void.



The ZRM 6006 is a high quality, state of the art instrument and is safe to operate. Nevertheless there is a chance of risk when the instrument is handled inappropriately.



Every person working with the ZRM 6006 or maintaining the ZRM 6006 must read and understand the manual completely. In particular the safety precautions and warnings.



The ZRM 6006 is exclusively intended for the determination of night visibility (RL) and/or day visibility (Qd) as well as ambient temperature (°C/°F) and relative humidity (rH %). Any other use is considered as not being in accordance with the intentions of the manufacturer. The manufacturer is not liable for damage resulting from inappropriate application. The user bears the full responsibility.







Proceq SA refuses all warranty and liability claims for damages caused by usage of the ZRM 6006 in combination with **non-original accessories**, or accessories from 3rd party suppliers.



Unauthorized modifications and changes of the ZRM 6006 are not allowed.



Reproduction without permission is not allowed.

-  All maintenance and repair work which is not explicitly allowed and described in the present instruction manual shall only be carried out by **Proceq SA** or your authorized Proceq agent, failure to comply voids warranty.
-  Keep the device dry. **Danger of short circuit!**
-  Make sure that the ZRM 6006 is unplugged from power supply and turned off before any maintenance.
-  For the operation of the ZRM 6006 apply all local safety regulations.

3 Delivery of device

3.1 Damages during carriage

On the receipt of the goods, check for any visible damages on the packaging. If it is undamaged you may sign the receipt of the goods. If you do suspect by your visual inspection that damage has occurred, make a note of the visible damage on the delivery receipt and request the courier to countersign it. Moreover, the courier service must be held responsible for the damage in writing.

If a hidden damage is discovered while unpacking, you have to inform and hold the courier liable immediately in the following way: "When opening the parcel we had to notice that ... etc." This superficial checking of the goods has to be done within the time limit set by the carrier, which is normally 7 days. However, the period could vary depending on the courier. Hence, it is recommended to check the exact time limit when receiving the goods.







If there are any damages also inform your authorized Proceq agent or **Proceq SA** immediately.

3.2 Shipment

Should the device be transported again, it must be packaged properly. Preferably use the original packaging for later shipments. Additionally use filling material in the package to protect the device from any shock during carriage.

3.3 Standard delivery

Following parts are included in the delivery:

1 ZRM 6006 Retroreflector	
1 calibration standard	
1 universal battery charger (100-240V, 50-60 Hz)	
1 certificate of manufacturer	
1 certificate of calibration	
1 carrying case with wheels	

3.4 Carrying case

The ZRM 6006 is delivered in a transportation case. Whenever you want to transport the instrument, use the case. Nevertheless, please take care that for shipments the case has to be put into a cardboard box and protected with filling material. The transportation case is an optimal storage case for the equipment. When not in use, The ZRM 6006 should be locked into the calibration standard and safely stowed in the carrying case.

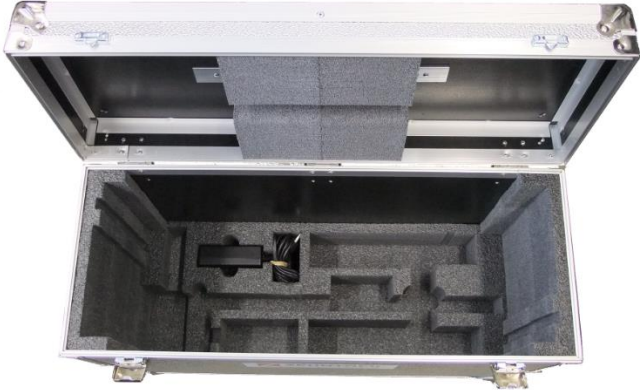

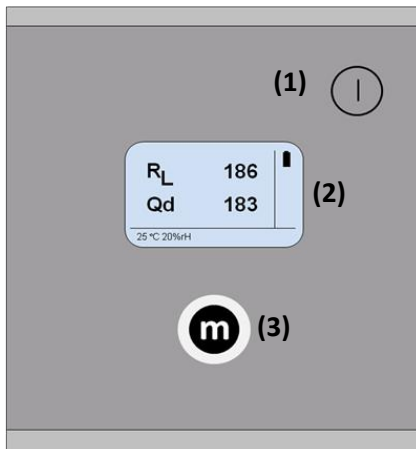

4 Device overview



- (1) On/off button
- (2) Display
- (3) Measuring button
- (4) Measuring area
- (5) Handle
- (6) Port for battery charger

5 Setting up

With a short press of the on/off button  the device is switched on or off. You will see the Zehntner-logo and the firmware version during switching on before the display changes into measuring mode.

For switching off the instrument you have to press the on/off button .

6 Calibrate

6.1 Calibrate

To ensure precise and valid results the ZRM 6006 must be calibrated by the user on the working standard in regular intervals (recommended interval: every 2 days).

Put the ZRM 6006 on the working standard, switch it on and press the measuring button longer than 5 seconds until the calibration values are shown on the display. Release the measuring button. The instrument is in calibration mode now. To execute a calibration, press the measuring button shortly.

CAL		
R _L	150	-
Q _d	150	-
PRESS M		

If the measuring button is not pressed within 2 seconds, the instrument switches back to measuring mode and the main screen will be displayed.

If the calibration is successful, a check  will be shown behind the calibration value. If the calibration value differs from the factory calibration by more than 15% an X will be displayed.

CAL		
R _L	150	✓
Q _d	150	X
PRESS M TO ACCEPT ANY		

Values with high deviation will not be accepted automatically. If the text "PRESS M TO ACCEPT ANY" is displayed and the measuring button is pressed the calibration out of range can be accepted.

CAL		
R _L	150	✓
Q _d	150	-
LED DEFECT 102		

If an error occurred during calibration, "-" will be displayed behind the calibration value. In this case it is not possible to accept the calibration value. Please contact Proceq SA or your authorized Proceq-agent.

 For calibration the device must be positioned exactly on the standard. Make sure that the snap-lock mechanism of the standard is attached correctly to the instrument.

6.2 Calibration standard

Always protect the calibration standard from dust, moisture and other environmental factors. It is recommended to keep it stored in the ZRM 6006 case. The standard values measured in the factory as well as the serial number of the corresponding instrument can be found on the sticker on the inside of the standard.

It is valid for 2 years and should be replaced or recalibrated by Zehntner after this time.

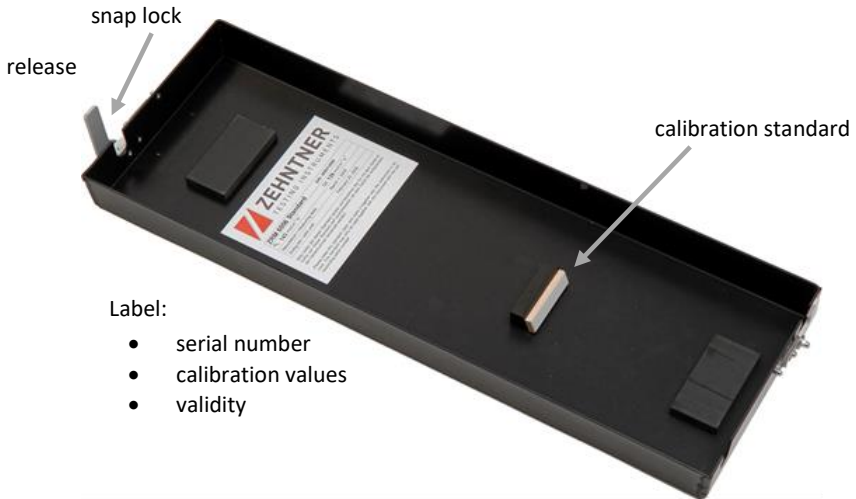

- ! The working standard delivered with the ZRM 6006 is not changeable and is valid only for the delivered instrument.

6.3 Cleaning of the calibration standard

If the calibration standard is soiled or covered by dust, it can be cleaned carefully using window cleaner and a soft tissue.

- ! A damaged or a polluted calibration standard may cause incorrect calibration and therefore incorrect measuring results.

7 Measure



After switching on the ZRM 6006 a splash screen is displayed, which shows the firmware version.

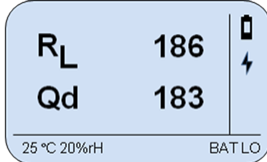

After about 2 seconds the instrument switches to the main screen, displaying the measured values, the temperature and the relative humidity. Additionally the battery and charger status and eventual warnings (BAT LO, BAT CRIT) are displayed.

To make a measurement press the measuring button shortly (not more than 4 seconds).

7.1 Carrying out exact measurements

The ZRM 6006 should be placed as even as possible. Put the ZRM 6006 on the sample or marking to be measured. For unevenness from -1 mm up to 5 mm in longitudinal direction, the given measuring geometry is warranted. Bigger unevenness may lead to wrong measuring results. Please observe in such cases the chapter 7.2 "Measuring profiled markings from 5-12 mm" as from page 16.

R_L

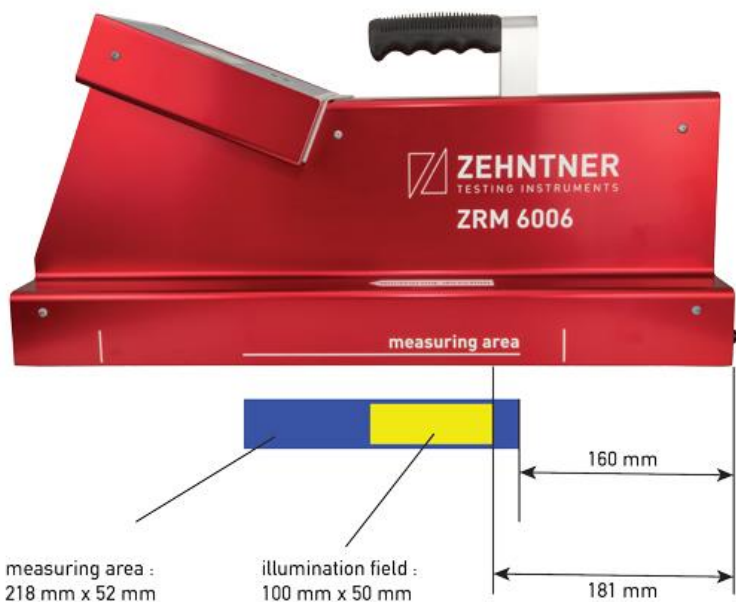

Q_d

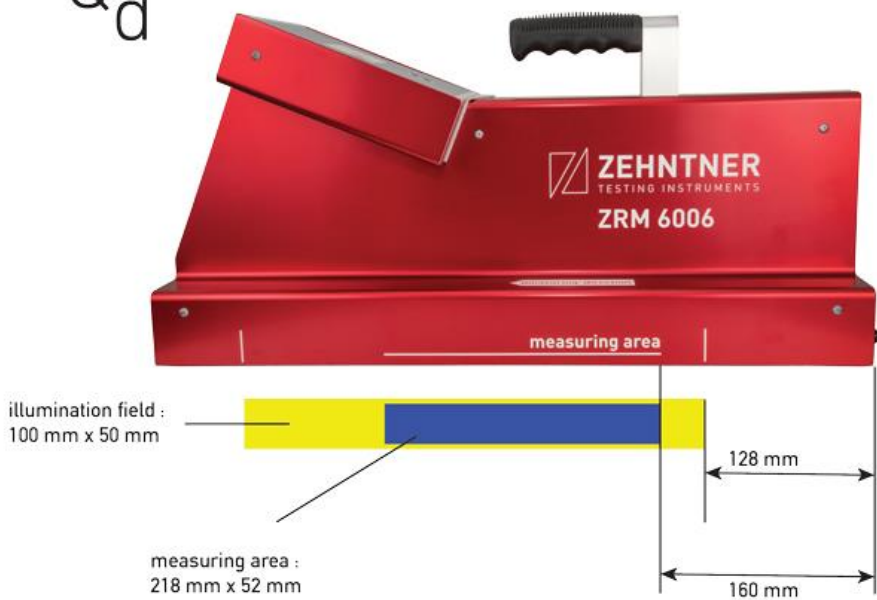

Ensure that the marking you want to measure is as flat as possible along in the whole range of the measuring instrument. Otherwise, the measuring geometry would be adulterated. Crooked or twisted samples will cause incorrect measuring results. For unevenness from -1 mm up to 5 mm, the given measuring geometry is warranted

The procedure for measurement in the laboratory is the same. Observe likewise that the samples are absolutely flat. The length of the samples should be at least 500 mm in order to guarantee that the instrument stands on all 3 feet.

- ! Make sure to use large enough, absolutely plane samples, insensitive to moisture, as e.g. sheet steel.

7.2 Measuring profiled markings from 5-12 mm

The ZRM 6006 is capable of measuring profiled road markings with profiles up to 5 mm. However, if the profile is higher than 5 mm you will need to follow a certain procedure in order to get reasonable values.

If the distance between the profiles is more than 300 mm, a support plate is needed with the same height as the profile to ensure the correct measuring geometries.

7.2.1 Getting started

- ! The procedure is shown on the ZRM 6013. The shown procedure is identical for the devices ZRM 6006, ZRM 6013 and ZRM 6013+.

Locate the two indicators on the Retroreflectometer “measuring area” and “measuring direction”. Point A is at the end of the arrow: “measuring direction”, Point B is at the end line of the “measuring area”. These indicators are located on both sides of the equipment.

When measuring a profiled road marking, the raised part of the road marking has to be located between point A and point B.

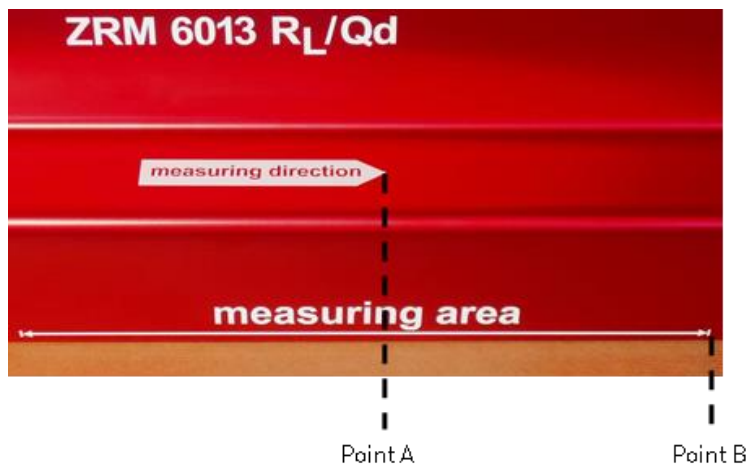

7.2.2 Measurements with profile distances under 300 mm

1. Place the instrument on the profile whereas Point B is on the middle of the profiled marking, take a measurement.



2. Move the instrument forward for approximately 5 cm and take the next measurement.



3. Move the instrument forward once again, so that Point A is in the middle of the profiled marking and take a measurement.



Chosen profile

4. Make the average value of the three measurements. Repeating this procedure on further measuring points ensures a better accuracy.

7.2.3 Measurements with profile distances over 300 mm

If the distance between two profiles of the marking is more than 300 mm, a support plate is needed to make sure the device sits even on the marking. The support plate has to have the same height as the profile of the marking to be measured.



support plate

profiled marking



Example of a support plate

The support plate has **always** to be placed at the rear side of the instrument and can reach maximum to the screws of the base plate. To all other side unlimited.

Correct placement of the support plate:

Side view of the unit



Bottom view of the unit, the support plate should be placed behind the base plate



Screws of the base plate

1. Place the instrument on the profile whereas Point B is on the middle of the profiled marking, take a measurement.



Chosen profile

2. Move the instrument and the support plate forward for approximately 5 cm and take the next measurement.



Chosen profile

3. Move the instrument together with the support plate forward once again, so that Point A is in the middle of the profiled marking and take a measurement.



Chosen profile

4. Make the average value of the three measurements. Repeating this procedure on further measuring points ensures a better accuracy.

7.2.4 Explanation of profile measurements

On the most profiled markings, the face of the profile gives back a higher value than the top of the profile. By moving the device and taking several measurements, you will get back a value that judges the face and the top of the profile.

Principle of R_L measurement: (The testing instruments are built in accordance with this illustration in reduced scale.)

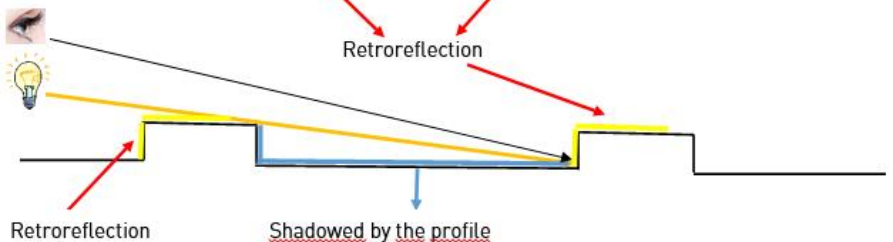
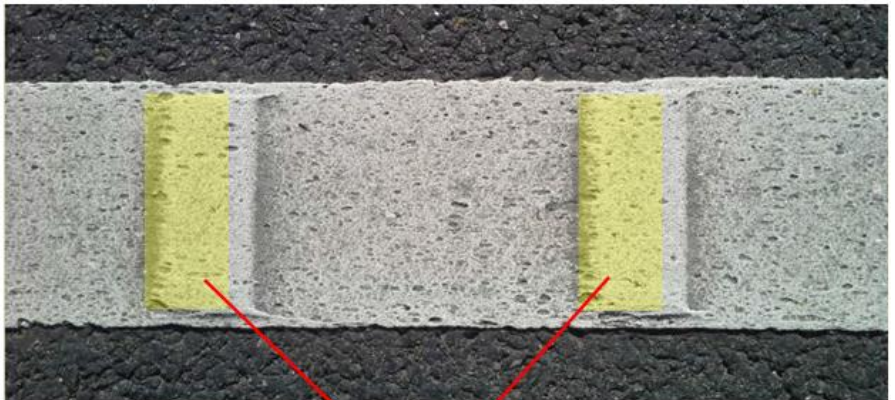
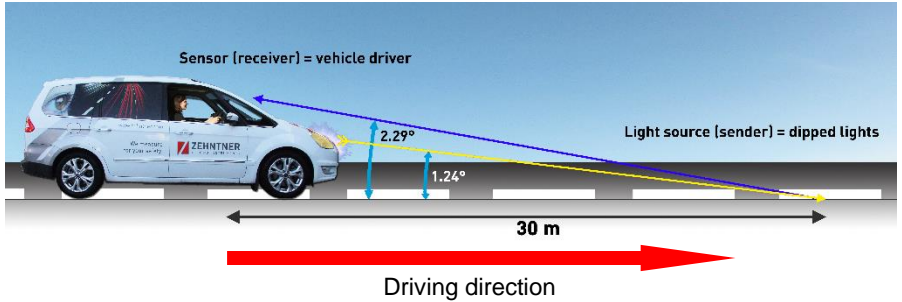

7.3 Wet measurements

The ZRM 6006 is perfectly suitable for measuring night and day visibility on wet roads and on moistened road markings (e.g. according to the “bucket” method)

- Set a timer (e.g. stopwatch) depending on the standards
 - Moisten the road marking in the required way, e.g. with the “bucket” method. The ZRM 6006 should be far enough away that it will not get wet.
 - Start the timer.
 - Wait until approx. 10 seconds before the timer setting expires and set the instrument onto the previously moistened road marking.
 - Start the measurement when the timer reached zero.
-
- ! Never pour water on the instrument.
 - ! Never dip the ZRM 6006 into water.
 - ! Do not expose the ZRM 6006 to the rain.

8 Built-in battery and charging

8.1 Battery

The used Li-Ion-Mn battery has a very high capacity. The capacity is continuously being observed. When the voltage becomes too weak the battery sign  appears on the display and the battery has to be charged.

In order to prevent a damage of the battery, the instrument switches automatically off before the battery is completely empty.

8.2 Battery status indication on the display



Battery is empty. The instrument switches automatically off.



Battery is soon empty. The instrument should be charged.



Battery is full.



Instrument is connected with the battery charger and the charging status is shown on the battery charger.

8.3 Charging



To charge the battery, plug in the charger plug on the ZRM 6006 and connect the charger to a wall socket (100 - 240 V, 50 - 60 Hz).

The special plug on the battery cable has a reverse polarity protection. The ZRM 6006 can be turned off or on while charging.





The battery charger may be connected to the ZRM 6006 also after finishing the charging

cycle as long as it is still connected to a wall socket. For disconnecting the charger press on the “push button” on the port for battery charger

8.3.1 Charging status indication / charging cycle

The charge indicator light on the charger shows the charge of the battery in the charging cycle:

- Is the indicator light red, the unit is fast charging. The battery charger is in constant current mode and the charge current is maximum.
- Is the indicator light orange, the charging cycle “final charge” is active. The battery is normally approx. 80% charged when the LED-indicator changes to orange. The battery charger is in constant voltage mode.
- Is the indicator light green, the battery is fully loaded.

-  Always charge the battery with the charger supplied.
-  If possible, the battery should always be charged completely which is shown with the green charging status indication light.
-  The battery may only be replaced by Proceq or by an authorized Proceq-agent.
-  If you have not used your ZRM 6006 during several months, the battery should be charged before using.

9 Maintenance

9.1 Maintenance carried out by the user

You may only carry out the following maintenance and repair yourself:

- Charging as described in chapter 8.3 on page 25.
- Cleaning as described in chapter 9.2 on page 26.

 All other maintenance and repair work may only be carried out by Proceq SA or your authorized Proceq agent, otherwise all warranty voids.

 Make sure that the ZRM 6006 is unplugged from power supply and turned off before any maintenance, except for charging.

 The instrument consists of sensitive optic and electronic precision parts. Protect it from shocks, moisture and dust. Please store the instrument in the transportation case.

9.2 Cleaning

We recommend that the instrument is checked and certified by Zehntner every two years. Otherwise clean the instrument periodically using water- and oil-free compressed air (max. 1.5 to 2 bar), or wipe the exit window on the bottom of the optics housing with a soft brush.

The exit window is coated with a special antireflection coating that should not be damaged. If the soft brush is not sufficient for cleaning the window, you may use a soft paper tissue and window cleaning liquid.

 The optics housing may not be opened under any circumstances since the measuring geometry would be misaligned. The measuring geometry can only be adjusted by means of special testing equipment in our factory.

10 Errors

In case an error message is shown on the display, please contact Proceq SA and indicate the language code and the number beneath shown on the display.

11 Graphical illustration of the measuring principles

11.1 Night visibility R_L

R_L is the coefficient of retroreflected luminance (night visibility) of road markings. The observation angle of 2.29° corresponds to the viewing distance of a vehicle driver of 30 m under normal conditions. The illumination angle is 1.24° .

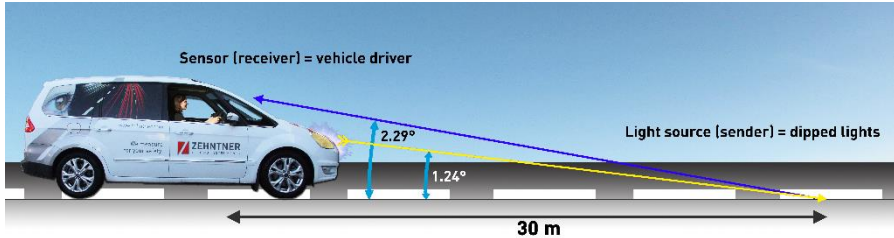

The angle definitions above are valid for EN 1436. It is important to understand that EN 1436 and ASTM E1710 use different illustration of the same angles.

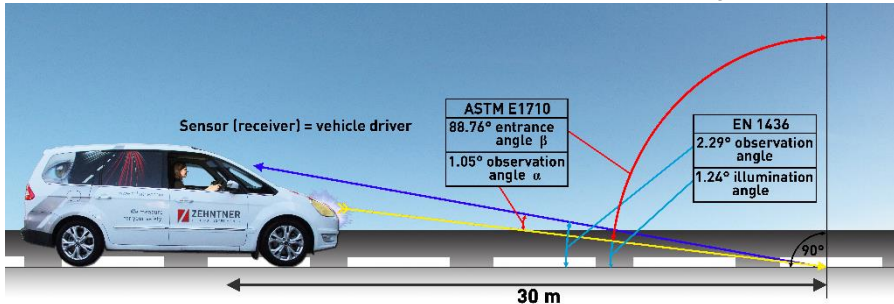

11.2 Day visibility

Q_d is the luminance coefficient under diffuse illumination (day visibility) of road markings. The observation angle of 2.29° corresponds to the viewing distance of a vehicle driver of 30 m under normal conditions. EN 1436 and ASTM E2302 use the same angle definitions.

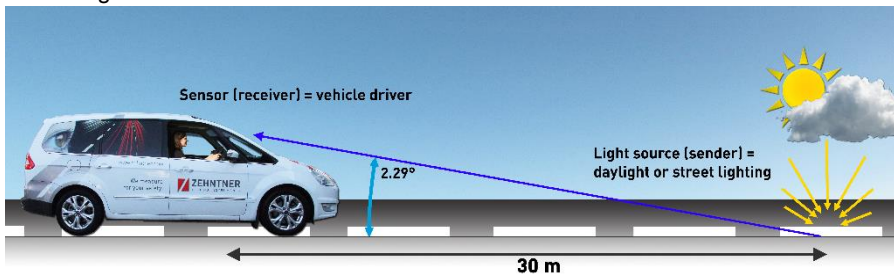

12 Technical specification

Observation distance:	30 m, according to CEN-geometry
Observation angle:	EN 1436: 2.29° ASTM E1710: 1.05° ASTM E2302: 2.29°
Illumination angle:	R _L : EN 1436: 1.24° R _L : ASTM E1710: 88.76° Q _d : diffuse
Measuring area:	52 mm x 218 mm
Measuring sensor:	adapted to V (λ)
Measuring range:	R _L : 0 - 4'000 mcd·m ⁻² ·lx ⁻¹ Q _d : 0 - 400 mcd·m ⁻² ·lx ⁻¹ profiled markings -1 mm up to 5 mm (-0.04" to 0.2"), up to 12 mm (0.5") with instruction
Measuring period:	approx. 2 seconds for R _L and Q _d
Memory:	none
Display:	transflective luminous graphical LCD display with LED backlight
External charger:	100 - 240 V / 50 - 60 Hz, 50 VA, universal
Battery:	Li-Ion-Mn, 14.4 V, 6.5 Ah
Charging time:	approx. 3 hours
Life cycle LED:	approx. 500'000 measurements
Operating:	- 10° C to + 50° C (14°F to 122°F), non condensing
Storage:	- 20° C to + 60° C (-4°F to 140°F), non condensing
Dimensions (LxWxH):	560 mm x 190 mm x 280 mm (22" x 7.5" x 11")
Weight:	6.4 kg (14.1 lbs) net
Warranty:	2 years
Standards:	EN 1436 (for R _L and Q _d) ASTM E1710 (for R _L) ASTM E 2302 (for Q _d) ASTM E 2177 (for R _L wet)

Glossary

A	
Accumulator	
Capacity	25
Replacing	26
Status charging	25
Status indication	25
Apparatus	
Specifications	29
B	
Battery	
Capacity	25
Charging	25
Replacing	26
Status indication	25
Battery and charging	25
C	
Calibration	12
Calibration standard	13
Cleaning	13
Cleaning	26
Calibration standard	13
D	
Damages during carriage	8
Day visibility Qd	28
Delivery of device	8
Description of device	6
Device overview	11
E	
Errors	27
Exclusion of liability	5
Extent of delivery	9
F	
Features	6
I	
Instrument	
Delivery	8
Description	6
Extent of delivery	9
M	
Maintenance	26
Charging	25
Cleaning	26
Measurements	
Profile distances over 300 mm ..	20
Profile distances under 300 mm	18
Profiled markings	17
Measuring angles	28
Measuring area	29
Measuring geometry	28
Measuring principle R _L and Q _d	28
N	
Night visibility R _L	28
P	
Profiled markings	16
S	
Safety information	7
Setting up	12
Shipment	8
Shut off	12
Specifications	29
Standard delivery	9
Starting up	12
Storage	
Temperature	29
Switching off	12

T

Technical specification 29
Transportation
 Damages 8

Turning off12
Turning-on12

W

Wet measurements.....24

